

6 DIGITAL MICRO-PROCESS RPM / LINE-SPEED / FREQUENCY METER with 2~4 ALARMS / ANALOG OUTPUT / RS-485

GR6

FEATURES

- Accuracy: $\pm 0.03\%$ F.S.; Input frequency: 400~10KHz; 100KHz (Custom Design)
- Measuring AC Frequency / DC Pulse / Magnetic
- High brightness dual LED display range: 0~999999; decimal point selectable
- Line-Speed / RPM / Frequency selectable; Line unit: M, Ft, Y/min selectable
- Baud rate up to 38400 bps; sampling time up to 60 cycles / sec
- Restore factory calibration setting available; Buzzer function available
- Dual input math function: B+A, B-A, (B/A) x 100, (B/A-1) x 100, [B/(A+B)] x 100
- 1~4 Alarms (Hi or Lo) programmable / Analog output (15 bit resolution) / RS-485 communication optional (The above options can exist together)
- High stability, non-flammable case (PC), high safety
- CE approval



ORDER INFORMATION: GR6 - [Code 1] [Code 2] - [Code 3] - [Code 4] [Code 5] [Code 6]

Code 1	Input Signal	Code 1	Input Signal	Code 2	Display Unit	Code 3	Aux. Power	Code 4	Alarm Output	Code 5	Analog Output	Code 6	RS-485
N5	NPN(5V)	VA	AC 2~60V	H	Hz	A	AC/DC 100~240V	N	None	N	None	N	None
N2	NPN(12V)	VB	AC 60~600V	R	RPM	D	AC/DC 22~60V	R2	2 Relays	A	4~20mA	Y	Yes
P5	PNP(5V)	VC	Pick-up 50mV~1.5V	M	M/min			R3	3 Relays	V	0~10V		
P2	PNP(12V)	VD	Pick-up 500mV~15V	Y	Y/min			R4	4 Relays	O	Option		
CT	Contact	VE	DC 24Vp	F	F/min			O2	2 Open Collect				
		O	Option					O3	3 Open Collect				
								O4	4 Open Collect				

SPECIFICATION

- ◆ Accuracy: $\pm 0.03\%$ F.S.
- ◆ Display Screen: High brightness red LED; 14.22mm(0.56")
- ◆ Sampling Cycle: 10 cycles / sec: >10Hz
f cycles / sec: <10Hz
- ◆ Display Range: 0~999999
- ◆ Over Range Indication: doFL / ioFL
- ◆ Polarity Indication: Automatic with "-" indication
- ◆ Parameters Setting: Push buttons
- ◆ Back Up Memory: EEPROM
- ◆ Alarm Action: " \geq (Hi) on" or "< (Lo) on"
- ◆ Alarm Run Delay Time: 0~99 sec
- ◆ Relay Contact: AC 277V / 7A; DC 30V / 7A
- ◆ Analog Output Resolution: 15 bit
- ◆ Output Response Time: <250 msec (0~90%)
- ◆ Output Capability: Voltage Output: <20mA
Current Output: <10V
- ◆ Communication: RS-485 Modbus RTU mode
- ◆ Baud Rate: 19200 / 9600 / 4800 / 2400 bps
- ◆ Temperature Coefficient: 100ppm / °C (0~60°C)
- ◆ Operating Temperature: 0~60°C
- ◆ Operating Humidity: 20~90% RH (non-condensing)
- ◆ Storage Temperature: -10~70°C
- ◆ Storage Humidity: 20~90% RH (non-condensing)
- ◆ Power Supply: AC/DC 100~240V; DC 12 / 24 / 30~90V
- ◆ Power Consumption: 8.5VA (all functions output)
- ◆ Surge Test: 1.5KVac / 1min (Input / Power)

FRONT PANEL & KEY FUNCTIONS

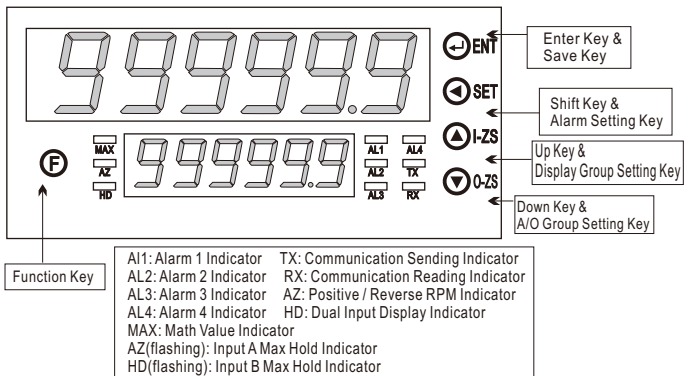

DIMENSION

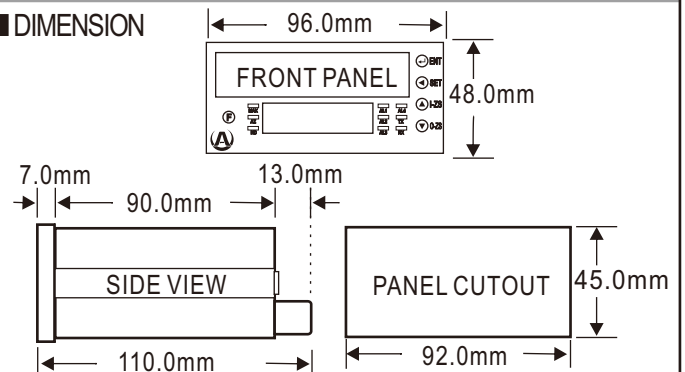

WIRING CONNECTION

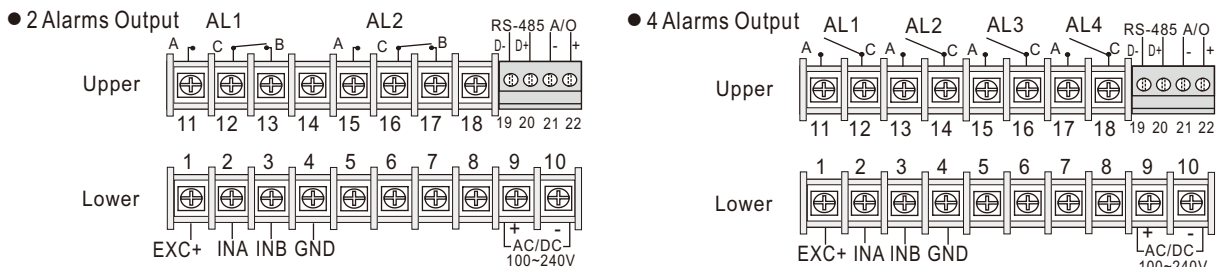

* Please understand key indicators & functions at the first operation.

1.1 FRONT PANEL

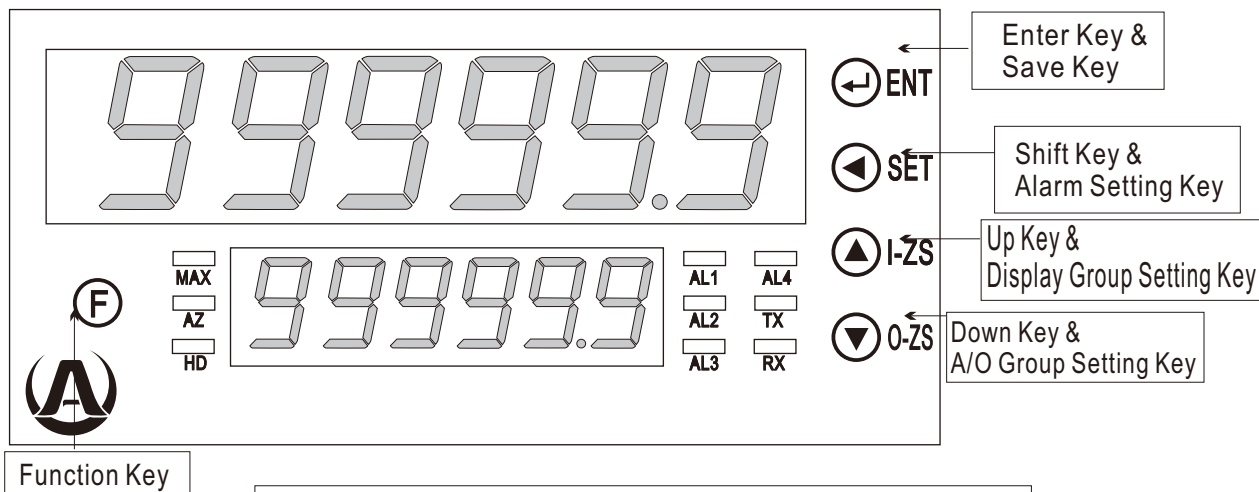

AL1: Alarm 1 Indicator TX: Communication Sending Indicator
 AL2: Alarm 2 Indicator RX: Communication Reading Indicator
 AL3: Alarm 3 Indicator AZ: Positive / Reverse RPM Indicator
 AL4: Alarm 4 Indicator HD: Dual Input Display Indicator
 MAX: Math Value Indicator
 AZ(flashing): Input A Max Hold Indicator
 HD(flashing): Input B Max Hold Indicator

1.2 KEY FUNCTIONS

Symbol	Key Name	Descriptions
Ⓢ	Function Key	1. No functions at the moment.
ENT	Enter Key & Save Key	1. In the measuring status, press this key can enter to parameter groups. 2. In the parameter setting, press this key can save the value & go to the next parameter.
←	Shift Key & Alarm Setting Key	1. In the measuring status, press this key for 3 sec can enter to Alarm Setpoint Modification. 2. In the parameter page, press this key can enter to parameter setting. 3. In the parameter setting, press this key can move the cursor left.
↑	Up Key & Display Group Setting Key	1. In the measuring status, press this key for 3 sec can enter to Display Group Setting. 2. In the parameter page, press this key can back to the last parameter page. 3. In the parameter setting, press this key can increase the digit.
↓	Down Key & A/O Group Setting Key	1. In the measuring status, press this key for 3 sec can enter to A/O Group Setting. 2. In the parameter page, press this key can go to the next parameter page. 3. In the parameter setting, press this key can decrease the digit.
↑ + ↓	Compound Key	1. In any status, press this key can back to measuring status. 2. While the buzzer acts, press this key can mute the buzzer.

1.3 DIMENSIONS

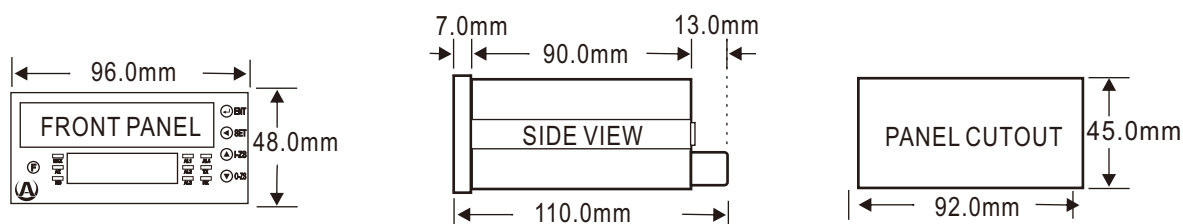

1.4 WIRING CONNECTION

2 Alarms Output:

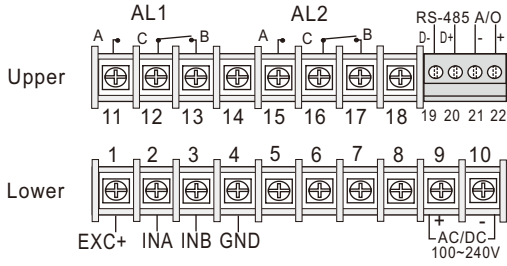

4 Alarms Output:

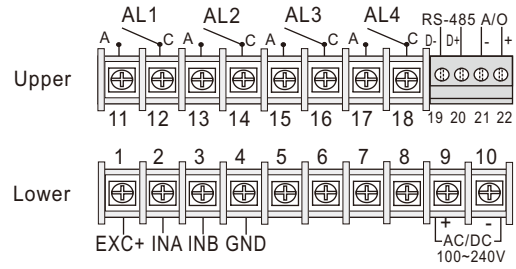

1.5 INPUT SIGNAL MODIFICATION

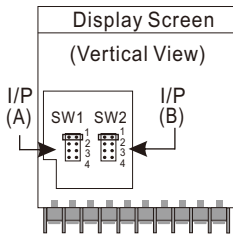

**To Select the pin to modify the input signal for different sensors.
PS: In dual input type, excitation power must be the same.

SW1/SW2	JUMPER	DEFINITION
	1	Open: 12V; Close: 5V
	2	Open: 10KHz; Close: 400Hz
	3	Open: NPN; Close: PNP
	4	Open: PNP; Close: NPN

**Connection:

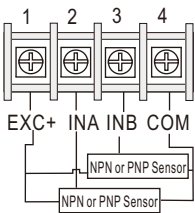

NPN (5V): 0~400 Hz

JUMPER	SW1/SW2
1	
2	
3	
4	

NPN (5V): 0~10 KHz

JUMPER	SW1/SW2
1	
2	
3	
4	

NPN (12V): 0~400 Hz

JUMPER	SW1/SW2
1	
2	
3	
4	

NPN (12V): 0~10 KHz

JUMPER	SW1/SW2
1	
2	
3	
4	

PNP (5V): 0~400 Hz

JUMPER	SW1/SW2
1	
2	
3	
4	

PNP (5V): 0~10 KHz

JUMPER	SW1/SW2
1	
2	
3	
4	

PNP (12V): 0~400 Hz

JUMPER	SW1/SW2
1	
2	
3	
4	

PNP (12V): 0~10 KHz

JUMPER	SW1/SW2
1	
2	
3	
4	

**Connection:

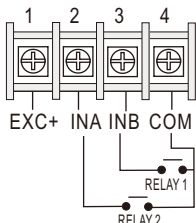

Relay Contact: NPN 0~400 Hz

JUMPER	SW1/SW2
1	
2	
3	
4	





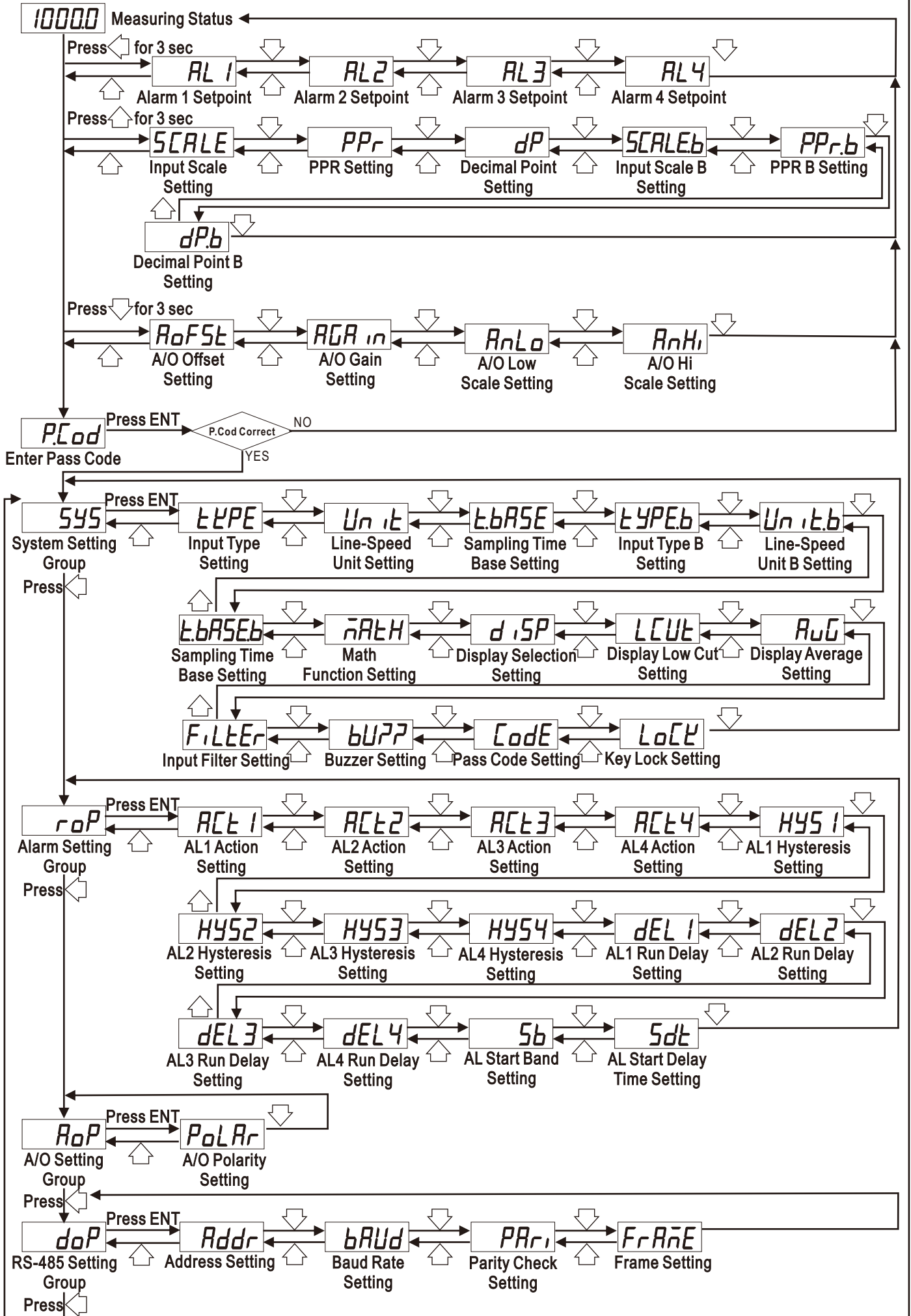

**For relay input type, please select NPN 0~ 400 Hz.

2.1 OPERATING SEQUENCE

















2.2 ALARM SETPOINT MODIFICATION

* In the measuring status, press  for 3 sec can enter to Alarm Setpoint Modification.

Display	Default	Name	Descriptions
	00000	Alarm 1 Setpoint (AL1)	1. Press  to enter the parameter setting, the digit will be flashed. 2. Press  or  can modify Alarm Setpoint. Range: 0~999999 3. Press ENT to save the value and go to the next parameter.
	00000	Alarm 2 Setpoint (AL2)	
	00000	Alarm 3 Setpoint (AL3)	
	00000	Alarm 4 Setpoint (AL4)	









2.3 DISPLAY SETTING









* In the measuring status, press  for 3 sec can enter to Display Group Setting.

Display	Default	Name	Descriptions
	10000	Input Scale Setting (SCALE)	1. Press  to enter the parameter setting, the digit will be flashed. 2. Press  or  can modify Input Scale. Range: 0.00001~9.99999 3. Press ENT to save the value and go to the next parameter.
	0000 1	PPR Setting (PPr)	1. Press  to enter the parameter setting, the digit will be flashed. 2. Press  or  can modify PPR. Range: 1~999999 3. Press ENT to save the value and go to the next parameter.
	00000	Decimal Point Setting (dp)	1. Press  to enter the parameter setting, the digit will be flashed. 2. Press  or  can select Decimal Point. Range: 0, 1, 2, 3, 4, 5 (DP) 3. Press ENT to save the value and back to Display Setting.
	10000	Input Scale B Setting (SCALE.b)	1. Please refer to "Input Scale Setting".
	0000 1	PPR B Setting (PPr.b)	1. Please refer to "PPR Setting".
	00000	Decimal Point B Setting (dp.b)	1. Please refer to "Decimal Point Setting".



2.4 A/O SETTING

* In the measuring status, press  for 3 sec can enter to A/O Group Setting.

Display	Default	Name	Descriptions
	00000	A/O Offset Setting (AoFSt)	1. Press  to enter the parameter setting, the digit will be flashed. 2. Press  or  can modify A/O Offset. Range: -9999~9999 3. Press ENT to save the value and go to the next parameter.
	00000	A/O Gain Setting (AGain)	1. Press  to enter the parameter setting, the digit will be flashed. 2. Press  or  can modify A/O Gain. Range: -9999~9999 3. Press ENT to save the value and go to the next parameter.

Display	Default	Name	Descriptions
	00000	A/O Low Scale Setting (AnLo)	<ol style="list-style-type: none"> Press  to enter the parameter setting, the digit will be flashed. Press  or  can modify A/O Low Scale. Range: 0~999999 If this value is 0, while display is 0, output signal will be 4 mAdc. Press ENT to save the value and go to the next parameter.
	99999	A/O Hi Scale Setting (AnHi)	<ol style="list-style-type: none"> Press  to enter the parameter setting, the digit will be flashed. Press  or  can modify A/O Hi Scale. Range: 0~999999 If this value is 100, while display is 100, output signal will be 20 mAdc. Press ENT to save the value and back to A/O Setting.

2.5 ERROR CODE OF SELF-DIAGNOSIS

Display	Descriptions
	Input signal is over 100 KHz of input range.
	Input signal is over display range (999999).
	EEPROM reading / writing suffers the interference (about 1 million times).





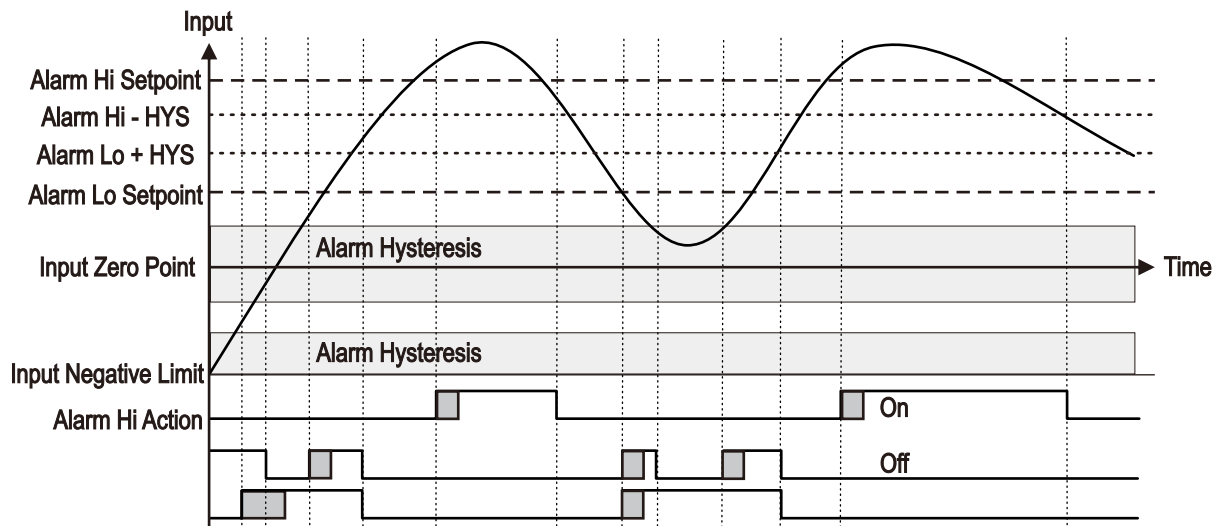









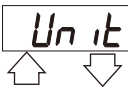







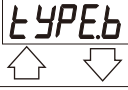
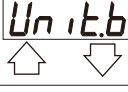





















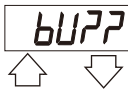

** Please check the wiring connection is correct first, if the problem still exist, please return the meter to the factory.

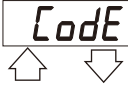
2.6 ALARM OUTPUT ACTION SEQUENCE

























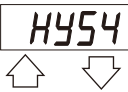





3.1 SYSTEM (SYS) SETTING GROUP PROCEDURE

* While Pass Code is correct, Press  can select System Setting Group.

Display	Default	Name	Descriptions
	Customers Specify	Input Type Setting (tYPE)	1. Press  to enter the parameter setting, the digit will be flashed. 2. Press  or  can select Input Type. Range: frEq (Frequency), rPM (RPM), LinE (Line-Speed) 3. Press ENT to save the value and go to the next parameter.
	Customers Specify	Line-Speed Unit Setting (Unit)	1. Press  to enter the parameter setting, the digit will be flashed. 2. Press  or  can select Line-Speed unit. Range: MEtEr (Meter), Foot (Foot), YArD (Yard) 3. Press ENT to save the value and go to the next parameter.
	1.0	Sampling Time Base Setting (t.bASE)	1. Press  to enter the parameter setting, the digit will be flashed. 2. Press  or  can modify Sampling Time Base. Range: 0.1~999.9 (sec) If this value is large, sampling time will become longer. 3. Press ENT to save the value and go to the next parameter.
	Customers Specify	Input Type B Setting (tYPE.b)	1. Please refer to "Input Input Type Setting".
	Customers Specify	Line-Speed Unit B Setting (Unit.b)	1. Please refer to "Line-Speed Unit Setting".
	1.0	Sampling Time Base B Setting (t.bASE.b)	1. Please refer to "Sampling Time Base B Setting".
	oFF	Math Function Setting (MATH)	1. Press  to enter the parameter setting, the digit will be flashed. 2. Press  or  can select Math Function. Range: oFF (None), Add.bA (B+A), Sub.bA (B-A), div.bA [(B/A)x100], Error [(B/A-1)x100], rAtio [(B/(A+B))x100] 3. Press ENT to save the value and go to the next parameter.
	ALArM	Display Selection Setting (diSP)	1. Press  to enter the parameter setting, the digit will be flashed. 2. Press  or  can select lower Display Selection. Range: ALArM (Alarm); RAte.A (Input AV); FrrPM (Reverse RPM); RAte.B (Input B Value); MAX (Input A Max Hold Value); MAX.b (Input B Max Hold Value) 3. Press ENT to save the value and go to the next parameter.
	00000	Display Low Cut Setting (LCUt)	1. Press  to enter the parameter setting, the digit will be flashed. 2. Press  or  can modify Display Low Cut. Range: 0~9999 If this value is 10, while display is under 10, display value will show 0. 3. Press ENT to save the value and go to the next parameter.
	00005	Display Average Setting (AvG)	1. Press  to enter the parameter setting, the digit will be flashed. 2. Press  or  can modify Display Average. Range: 1~99 If this value is large, display will be stable & smooth. 3. Press ENT to save the value and go to the next parameter.
	oFF	Input Filter Setting (FiLteR)	1. Press  to enter the parameter setting, the digit will be flashed. 2. Press  or  can select Input Filter. Range: 4000, 400, 40, 4, oFF (Hz) If this value is 400, the input signal will be filtered above 400 Hz. 3. Press ENT to save the value and go to the next parameter.
	no	Buzzer Setting (bUZZ)	1. Press  to enter the parameter setting, the digit will be flashed. 2. Press  or  can close Buzzer. Range: no (Do Not Close), YES (Close) 3. Press ENT to save the value and go to the next parameter.
	00000	Pass Code Setting (P.Cod)	1. Press  to enter the parameter setting, the digit will be flashed. 2. Press  or  can modify Pass Code. Range: 0~19999 (Please do remember new Pass Code) 3. Press ENT to save the value and go to the next parameter.
	no	Key Lock Setting (LoCK)	1. Press  to enter the parameter setting, the digit will be flashed. 2. Press  or  can close Key Lock. Range: no (Do Not Close), YES (Close) 3. Press ENT to save the value and back to System Setting Group.





3.2 ALARM (roP) SETTING GROUP PROCEDURE

* While Pass Code is correct, Press  can select Alarm Output Setting Group.

Display	Default	Name	Descriptions
	H I	AL1 Action Setting (ACT1)	1. Press  to enter the parameter setting, the digit will be flashed. 2. Press  or  can select Alarm Action. Range: Hi (\geq Alarm Setpoint On), Lo ($<$ Alarm Setpoint On) 3. Press ENT to save the value and back to A/O Group Setting.
	H I	AL2 Action Setting (ACT2)	
	H I	AL3 Action Setting (ACT3)	
	H I	AL4 Action Setting (ACT4)	
	00000	AL1 Hysteresis Setting (HYS1)	1. Press  to enter the parameter setting, the digit will be flashed. 2. Press  or  can modify Alarm Hysteresis. Range: 0~9999 Alarm will be turned off while display value is higher or lower (depends on Alarm Action) Alarm Setpoint +/- Hysteresis. 3. Press ENT to save the value and go to the next parameter.
	00000	AL2 Hysteresis Setting (HYS2)	
	00000	AL3 Hysteresis Setting (HYS3)	
	00000	AL4 Hysteresis Setting (HYS4)	
	00000	AL1 Run Delay Setting (dEL1)	1. Press  to enter the parameter setting, the digit will be flashed. 2. Press  or  can modify Alarm Run Delay. Range: 0~99 (sec) Alarm will be turned on after this setting (sec). 3. Press ENT to save the value and go to the next parameter.
	00000	AL2 Run Delay Setting (dEL2)	
	00000	AL3 Run Delay Setting (dEL3)	
	00000	AL4 Run Delay Setting (dEL4)	
	00000	AL Start Band Setting (Sb)	1. Press  to enter the parameter setting, the digit will be flashed. 2. Press  or  can modify Alarm Start Band. Range: 0~99 If display value do not over this setting, alarm will not be turned on. 3. Press ENT to save the value and go to the next parameter.
	00000	AL Start Delay Time Setting (Sdt)	1. Press  to enter the parameter setting, the digit will be flashed. 2. Press  or  can modify Alarm Start Delay Time. Range: 0~99 (sec) If display value reach Alarm Start Band, alarm will be turned on after this setting (sec). P.S.: This function must use with "Sb" together. 3. Press ENT to save the value and back to Alarm Setting Group.















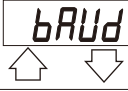

3.3 A/O (A_oP) SETTING GROUP PROCEDURE

* While Pass Code is correct, Press  can select A/O Setting Group.

Display	Default	Name	Descriptions
	<i>no</i>	A/O Polarity Setting (PoLAr)	1. Press  to enter the parameter setting, the digit will be flashed. 2. Press  or  can select A/O Polarity. Range: no (Positive Pole O/P; 0~10 Vdc), YES (Positive & Negative Pole O/P; -10~+10 Vdc) 3. Press ENT to save the value and back to A/O Setting Group.

3.4 RS-485 (d_oP) SETTING GROUP PROCEDURE

* While Pass Code is correct, Press  can select RS-485 Setting Group.

Display	Default	Name	Descriptions
	<i>00000</i>	Address Setting (Addr)	1. Press  to enter the parameter setting, the digit will be flashed. 2. Press  or  can modify Address. Range: 0~255 3. Press ENT to save the value and go to the next parameter.
	<i>38400</i>	Baud Rate Setting (bAUd)	1. Press  to enter the parameter setting, the digit will be flashed. 2. Press  or  can select Baud Rate. Range: 38400, 19200, 9600, 4800 (bps) 3. Press ENT to save the value and go to the next parameter.
	<i>n8.2.</i>	Parity Check Setting (PAri)	1. Press  to enter the parameter setting, the digit will be flashed. 2. Press  or  can select Parity Check. Range: n.8.2., n.8.1., EvEn, odd 3. Press ENT to save the value and go to the next parameter.
	<i>no</i>	Frame Setting (FrAmE)	1. Press  to enter the parameter setting, the digit will be flashed. 2. Press  or  can select Frame. Range: no (Hi to Lo), YES (Lo to Hi) 3. Press ENT to save the value and back to RS-485 Setting Group.

4.1 MODBUS RTU MODE PROTOCOL ADDRESS TABLE

* Data form: 16 / 32 bit, +/-8000~7FFF(-32768~32767), 800000007FFFFFFF(-2147483648~2147483647)

Modbus	Hex	Name	Act	Descriptions
40001	0000	ID	R	Model number identification; GR6 is 2A
40002	0001	STATUS	R	Current alarm output & external control input status, range: 0000~00F0 (0~240) (Bit 7: AL4, Bit 6: AL3, Bit 5: AL2, Bit 4: AL1, Bit 3: Buzz) 0:Off, 1:On
40003	0002	INDEX	R/W	Index, range: 0000~0035 (0~53) [Please refer section 4.2 for detail.]
40004	0003	LOCK	R/W	Key lock setting, range: 0000~0001 (0~1); 0:No, 1:YES
40005	0004	FILTER	R/W	Input filter setting, range: 0000~0004 (0~4); 0:4000, 1:400, 2:40, 3:4, 4:oFF
40006	0005	BUZZ	R/W	Buzzer setting, range: 0000~0001 (0~1); 0:No, 1:YES
40007	0006	MATH	R/W	Math function setting, range: 0000~0005 (0~5); 0:oFF, 1:Add.bA, 2:Sub.bA, 3:div.bA, 4:Error, 5:rAtio
40008	0007	DISP	R/W	Display selection setting, range: 0000~0005 (0~5); 0:ALArM, 1:MAth.v, 2:FrrPM, 3:dUALiP, 4:MAX, 5:MAX.b
40009	0008	POLAR	R/W	Polar setting, range: 0000~0001 (0~1); 0:No, 1:YES
40010	0009	ACT1	R/W	Alarm 1 action setting, range: 0000~0001 (0~1); 0:Hi, 1:Lo
40011	000A	ACT2	R/W	Alarm 2 action setting, range: 0000~0001 (0~1); 0:Hi, 1:Lo
40012	000B	ACT3	R/W	Alarm 3 action setting, range: 0000~0002 (0~2); 0:Hi, 1:Lo, 2:Go
40013	000C	ACT4	R/W	Alarm 4 action setting, range: 0000~0001 (0~1); 0:Hi, 1:Lo
40014	000D	PARI	R/W	Parity check setting, range: 0000~0003 (0~3); 0:n.8.2., 1:n.8.1., 2:EvEn, 3:odd
40015	000E	BAUD	R/W	Baud rate setting, range: 0000~0003 (0~3); 0:38400, 1:19200, 2:9600, 3:4800
40016	000F	FRAME	R/W	Frame setting, range: 0000~0001 (0~1); 0:No, 1:YES
40017	0010	TYPE	R/W	Input type setting, range: 0000~0002 (0~2); 0:rPM, 1:Line-Speed, 2:Frequency
40018	0011	TYPE.B	R/W	Input type B setting, range: 0000~0002 (0~2); 0:rPM, 1:Line-Speed, 2:Frequency
40019	0012	UNIT	R/W	Line-Speed unit setting, range: 0000~0002 (0~2); 0:MEtEr, 1:Foot, 2:YArD
40020	0013	UNIT.B	R/W	Line-Speed unit B setting, range: 0000~0002 (0~2); 0:MEtEr, 1:Foot, 2:YArD
40021	0014	DP	R/W	Decimal point setting, range: 0000~0005 (0~5); 0:10 ⁰ , 1:10 ⁻¹ , 2:10 ⁻² , 3:10 ⁻³ , 4:10 ⁻⁴ , 5:10 ⁻⁵
40022	0015	DP.B	R/W	Decimal point B setting, range: 0000~0005 (0~5); 0:10 ⁰ , 1:10 ⁻¹ , 2:10 ⁻² , 3:10 ⁻³ , 4:10 ⁻⁴ , 5:10 ⁻⁵
40023	0016	AVG	R/W	Display average setting, range: 0001~0063 (1~99)
40024	0017	ADDR	R/W	Address setting, range: 0000~00FF (0~255)
40025	0018	DEL1	R/W	Alarm 1 run delay setting, range: 0000~0063 (0~99)
40026	0019	DEL2	R/W	Alarm 2 run delay setting, range: 0000~0063 (0~99)
40027	001A	DEL3	R/W	Alarm 3 run delay setting, range: 0000~0063 (0~99)
40028	001B	DEL4	R/W	Alarm 4 run delay setting, range: 0000~0063 (0~99)
40029	001C	SB	R/W	Alarm start band setting, range: 0000~0063 (0~99)
40030	001D	SDT	R/W	Alarm start delay time setting, range: 0000~0063 (0~99)
40031	001E	LCUT	R/W	Display low cut setting, range: 0000~270F (0~9999)
40032	001F	CODE	R/W	Pass code setting, range: 0000~4E1F (0~19999)
40033	0020	T.BASE	R/W	Sampling time base setting, range: 0001~270F (1~9999)
40034	0021	T.BASE.B	R/W	Sampling time base B setting, range: 0001~270F (1~9999)
40035	0022	HYS1	R/W	Alarm 1 hysteresis setting, range: 0000~270F (0~9999)
40036	0023	HYS2	R/W	Alarm 2 hysteresis setting, range: 0000~270F (0~9999)
40037	0024	HYS3	R/W	Alarm 3 hysteresis setting, range: 0000~270F (0~9999)
40038	0025	HYS4	R/W	Alarm 4 hysteresis setting, range: 0000~270F (0~9999)
40039	0026	AOFST	R/W	A/O offset setting, range: D8F1~270F (-9999~9999)
40040	0027	AGAIN	R/W	A/O gain setting, range: D8F1~270F (-9999~9999)
40041	0028	PPR	R/W	PPR setting, range: 00000001~000F423F (1~999999) Hi Bit
40042	0029		R/W	PPR setting, range: 00000001~000F423F (1~999999) Lo Bit
40043	002A	PPR.B	R/W	PPR B setting, range: 00000001~000F423F (1~999999) Hi Bit
40044	002B		R/W	PPR B setting, range: 00000001~000F423F (1~999999) Lo Bit
40045	002C	SCALE	R/W	Input scale setting, range: 00000001~000F423F (1~999999) Hi Bit
40046	002D		R/W	Input scale setting, range: 00000001~000F423F (1~999999) Lo Bit

Modbus	Hex	Name	Act	Descriptions
40047	002E	SCALE.B	R/W	Input scale B setting, range: 00000001~000F423F (1~999999) Hi Bit
40048	002F		R/W	Input scale B setting, range: 00000001~000F423F (1~999999) Lo Bit
40049	0030	ANLO	R/W	A/O low scale setting, range: 00000000~000F423F (0~999999) Hi Bit
40050	0031		R/W	A/O low scale setting, range: 00000000~000F423F (0~999999) Lo Bit
40051	0032	ANHI	R/W	A/O hi scale setting, range: 00000000~000F423F (0~999999) Hi Bit
40052	0033		R/W	A/O hi scale setting, range: 00000000~000F423F (0~999999) Lo Bit
40053	0034	AL1	R/W	Alarm 1 setpoint setting, range: 00000000~000F423F (0~999999) Hi Bit
40054	0035		R/W	Alarm 1 setpoint setting, range: 00000000~000F423F (0~999999) Lo Bit
40055	0036	AL2	R/W	Alarm 2 setpoint setting, range: 00000000~000F423F (0~999999) Hi Bit
40056	0037		R/W	Alarm 2 setpoint setting, range: 00000000~000F423F (0~999999) Lo Bit
40057	0038	AL3	R/W	Alarm 3 setpoint setting, range: 00000000~000F423F (0~999999) Hi Bit
40058	0039		R/W	Alarm 3 setpoint setting, range: 00000000~000F423F (0~999999) Lo Bit
40059	003A	AL4	R/W	Alarm 4 setpoint setting, range: 00000000~000F423F (0~999999) Hi Bit
40060	003B		R/W	Alarm 4 setpoint setting, range: 00000000~000F423F (0~999999) Lo Bit
40061	003C	RATE	R	Current display value, range: 00000000~000F423F (0~999999) Hi Bit
40062	003D		R	Current display value: range: 00000000~000F423F (0~999999) Lo Bit
40063	003E	RATE.B	R	Current display value B, range: 00000000~000F423F (0~999999) Hi Bit
40064	003F		R	Current display value B, range: 00000000~000F423F (0~999999) Lo Bit
40065	0040	MATH.V	R	Math value, range: FFFCF2C1~000F423F (-199999~999999) Hi Bit
40066	0041		R	Math value, range: FFFCF2C1~000F423F (-199999~999999) Lo Bit
40067	0042	MAX	R	Input A max hold value, range: 00000000~000F423F (0~999999) Hi Bit
40068	0043		R	Input A max hold value, range: 00000000~000F423F (0~999999) Lo Bit
40069	0044	MAX.B	R	Input B max hold value, range: 00000000~000F423F (0~999999) Hi Bit
40070	0045		R	Input B max hold value, range: 00000000~000F423F (0~999999) Lo Bit

4.2 INDEX CODE SUPPLEMENT

* The following codes are for hexadecimal.

Page / Name	Page / Name	Page / Name	Page / Name	Page / Name
00: SYS	01: roP	02: AoP	03: doP	04: P.Cod
05: E-00	06: LoCK	07: FiLtEr	08: bUZZ	09: MATh
0A: diSP	0B: PoLAr	0C: ACT1	0D: ACT2	0E: ACT3
0F: ACT4	10: PAri	11: bAUd	12: FrAME	13: tYPE
14: tYPE.b	15: Unit	16: Unit.b	17: dP	18: dP.b
19: AvG	1A: Addr	1B: dEL1	1C: dEL2	1D: dEL3
1E: dEL4	1F: Sb	20: Sdt	21: LCUt	22: CodE
23: t.bASE	24: t.bASE.b	25: HYS1	26: HYS2	27: HYS3
28: HYS4	29: AoFSt	2A: AGAin	2B: PPr	2C: PPr.b
2D: SCALE	2E: SCALE.b	2F: AnLo	30: AnHi	31: AL1
32: AL2	33: AL3	34: AL4	35: Current Display	